

Investigations on Characteristic Parameters and Power Degradation of Amorphous Silicon Solar Modules Based on Long-Term Outdoor Testing

Marwan M. Mahmoud

Renewable Energy Research Centre, An Najah National University
Nablus P.O.Box 7 - West Bank
PALESTINE

ABSTRACT

Two types of amorphous silicon PV modules have been exposed for outdoor testing, under severe natural environmental conditions, for a period of three years. The tests were conducted to measure the current-voltage (I-V) curve as a function of solar radiation and ambient temperature. Test results were analyzed under consideration of the presented equivalent circuit, for a hydrogenated amorphous silicon solar cell or module (α -Si:H), with the respective mathematical model. The test system and procedure are explained. Based on continuous measurements, climatic conditions of the test site are presented. Test results show that the shunt resistance R_{sh} and series resistance R_s , represented in the equivalent circuit of the amorphous module, change their initial values remarkably as a function of the exposure time. Relation between the variation of R_{sh} , R_s and the degradation of the module is illustrated. Extensive degradation in the peak power, the efficiency, and fill factor of each amorphous module type, especially during the first 1.5 years of the test period, were measured. Contrary to some previous studies, the degradation does not stabilize totally after one year of operation

1. INTRODUCTION

The 1980s included fast spreading of photovoltaic power systems in a wide range of applications varying from few peak watts to megawatts plants. Most of these systems were of monocrystalline or polycrystalline silicon type. The systems covered a wide field of applications including communications, water-pumping, cathodic protection, rural electrification and supply of electric grids. Only a very small portion of these systems (with relatively very low peak power) were of amorphous silicon type. Since the cost of mono- and polycrystalline silicon solar cells was too high at the beginning of 1980s (US\$ 10 to US\$ 20/peak Watt), a factor which made the feasibility of using these types questionable, the amorphous silicon solar cells won in USA, Japan and Germany a remarkable attention.

The main advantage of amorphous technology as compared to crystalline technology lies in less energy and raw material requirements for production of modules, which lead to cheaper production. According to Hagedorn [1], crystalline modules require an energy investment of about 16 kWh per peak watt (W_p) and 30.5 gram of silicon per W_p corresponding to a production cost of US\$ 2.5/ W_p . In comparison, amorphous modules require only 6.5 kWh per W_p and 0.35 gram of pure silicon per W_p corresponding to a production cost of US\$ 1.5/ W_p [2].

Therefore, extensive efforts aiming at raising the initial efficiency and investigating different new thin film technologies had been made at research centers worldwide. During the 1980s the initial efficiency of amorphous silicon solar cell could be improved from 2% to 7%. This achievement was encouraging to many suspicious users all over the world to start considering seriously the use of amorphous silicon in their PV power programs. Fortunately, the applications of this type were only limited to small systems and consumer products, because a heavy degradation in the efficiency (20%)

even during the first year of operation was registered. This disappointing result caused a reduction in the demand on amorphous PV in the world markets. The producers of amorphous PV modules claimed that the drop in the efficiency would only occur during the first year of operation and after that it will stabilize and remain constant at an acceptable value. In fact, the experience presented in this paper shows that the efficiency continued its degradation linearly with time even after the first year of operation. The efficiency of some module types dropped from 6% to 3.8% during the first three years of operation. This degradation corresponds to an increase in the initial PV-price of about 30%.

2. SOLAR CELL MODEL AND CHARACTERISTIC

In general, an illuminated crystalline silicon solar cell (*C-Si*), consisting of only *pn* layers, is usually represented by its equivalent circuit illustrated in Fig. 1 (without the dependent current source branch). This circuit consists of the dark diode characteristic superposed with a photocurrent source I_{ph} . The series and shunt resistance R_s , R_{sh} , respectively, describe the quality and behavior of the real solar cell.

On the other hand, an amorphous silicon solar cell can be realized on the basis of hydrogenated amorphous silicon *a-Si:H* and can be considered as a pin-diode. As known, the main part of the current generation occurs in the intrinsic *i*-layer. Thus this cell behaves differently from *C-Si*.

According to Merten, et al. [3] recombination is relatively intense within amorphous silicon cells because of the presence of dangling bonds that act as recombination centers.

Therefore it is reasonable to describe an amorphous silicon cell by introducing an additional recombination loss term I_{rec} into the equivalent circuit, a term which is symbolized by the dependent current source in Fig. 1. Recombination losses within the *i*-layer are in a first approximation proportional to the carrier concentration therein, and thus to the photo generated current I_{ph} [4].

The recombination function in the *i*-layer is given by Hubin, et al. [5] as :

$$F(x) = \frac{n_f}{\tau_n} + \frac{p_f}{\tau_p} \quad (1)$$

Where τ_n and τ_p are the capture time of the electrons (n_f) and holes (p_f) by the neutral dangling bonds. Assuming a constant electric field $|E|$ within the *i*-layer and a homogenous generation of carriers, which leads to linearly varying profiles for the free electrons n_f and holes p_f , the recombination function can be integrated over the whole *i*-layer, (from $x = 0$ to $x = d_i$) to obtain the total current loss I_{rec} due to recombination [3]:

$$I_{rec} = \int_0^{d_i} F(x) dx \quad (2)$$

$$I_{rec} = I_{ph} \frac{d_i^2}{(\mu\tau)_{eff} [V_{bi} - (V - R_s I)]} \quad (3)$$

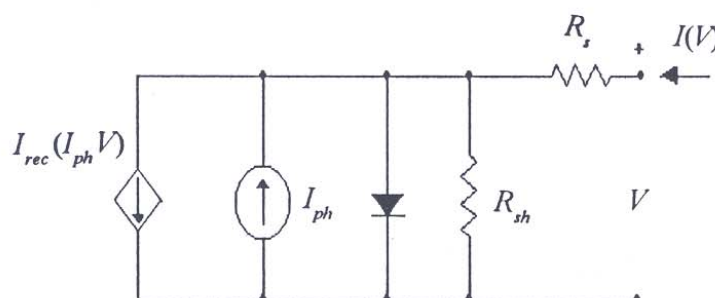

Fig. 1. Equivalent circuit for amorphous photovoltaic cell or module.

Where d_i is the i -layer thickness, V_{bi} the built-in voltage, μ the mobility, V and I the terminal voltage and current, respectively, and $(\mu\tau)_{eff}$ - product combines with $(\mu\tau)$ - product of electrons and holes together within the i -layer of the cell. The effective drift length in the i -layer is defined as: $(\mu\tau)_{eff} \times |E|$.

Introducing this recombination current into the equivalent circuit in Fig. 1 leads to the following expression for the $I(V)$ curve of amorphous silicon solar cells and modules:

$$I(V) = -I_{ph} + I_{ph} \frac{d_i^2}{(\mu\tau)_{eff} [V_{bi} - (V - R_s I)]} + I_0 [\exp(V - R_s I) / (nkT/e) - 1] + \frac{(V - R_s I)}{R_{sh}} \quad (4)$$

It is obvious that the photo-generated current I_{ph} is reduced by the loss currents due to recombination in the i -layer, by the diode with its saturation current I_0 and its quality factor n and by the shunt resistance R_{sh} (e is the elementary charge, k the Boltzmann's constant and T the absolute temperature of the device).

Considering only the recombination term in Eq. (4), the slope within the short circuit region yields the value of the short circuit resistance R_{sc} [4].

$$R_{sc} = \frac{(\mu\tau)_{eff} V_{bi}^2}{d_i^2 I_{ph}} \quad (5)$$

This means that measurement of R_{sc} provides direct information about the effective $(\mu\tau)_{eff}$ - product within the i -layer and thereby about the degradation.

The built-in voltage in amorphous silicon solar cells was determined in a study by Mahmoud and Nabhan [6] to be $V_{bi} = 0.9$ V. In studying the degradation effect, it is necessary to differentiate the $I(V)$ curve in Fig. 2 of the cell or module at short circuit and open circuit points, where the reciprocal values for the short circuit resistance (R_{sc}) are obtained which is related to R_{sh} , as well as the open circuit resistance (R_{oc}), which is related to R_s in the equivalent circuit:

$$\frac{1}{R_{sc}} = \left(\frac{dI}{dV} \right)_{V=0} \quad (6)$$

$$\frac{1}{R_{oc}} = \left(\frac{dI}{dV} \right)_{I=0} \quad (7)$$

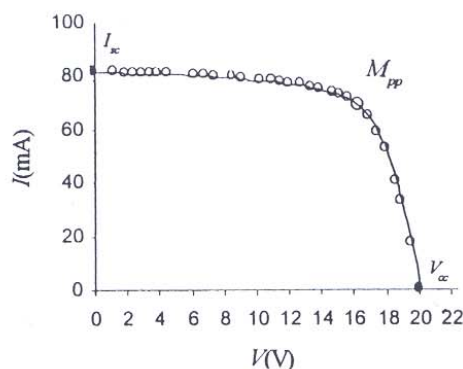

Fig. 2. Measured I - V curve of a new amorphous silicon solar module with an area of 203 cm^2 , at $G = 950 \text{ W/m}^2$ and $T_{pv} = 53^\circ\text{C}$.

R_{sc} and R_{oc} which are the reciprocal slopes of the $I(V)$ curve are key parameters for degradation effect of the i -layer material of the a - $Si:H$, which is known as Steabler-Wronski effect [9]. For crystalline silicon, R_{sc} is mostly equal to the shunt resistance R_{sh} of the cell over a large range of illumination levels [6-7]. Merten [3] reports according to his experimental investigations that this is not the case for amorphous silicon cells. Based from Eq. (4) the slope R_{sc} is equal to the shunt resistance R_{sh} only in the low illumination limit. On the other hand, the model results in R_{oc} being equal to R_s of the cell or module in the high illumination range.

Hence, by evaluation of the experimental results in section 4, the relation between these parameters (R_{sc} , R_{oc}) and the power degradation of the amorphous silicon modules are highly considered. Furthermore, the effect of degradation on the peak power (P_{max}), the fill factor (F_f), and the efficiency of a solar cell or module should be determined and are computable through the following equations [6]:

$$P_{max} = V_{mpp} I_{mpp} \quad (8)$$

$$F_f = \frac{P_{max}}{V_{oc} I_{sc}} \quad (9)$$

$$\eta_{pv} = \frac{P_{max}}{G A_{pv}} \quad (10)$$

Where V_{mpp} and I_{mpp} are voltage and current at the maximum power point, respectively, V_{oc} and I_{sc} are the open circuit voltage and short circuit current, respectively, A_{pv} is the area of the solar cell or module, and G is the solar radiation intensity on the cell surface.

3. EXPERIMENTAL PROCEDURE

Measuring the $I-V$ characteristic of a PV module at different solar radiation intensities and cell temperatures, for a long period, is the most effective method for evaluation of its performance. While a test period of at least five years would be necessary for mono - and polycrystalline silicon PV modules, a period of two to three years is enough to give evidence on the performance of amorphous silicon PV- module types since the latter type degrades faster .

In order to measure the $I-V$ characteristic of several PV- modules in a short time, an automatic measuring system was designed and used [7]. This system is illustrated in Fig. 3.

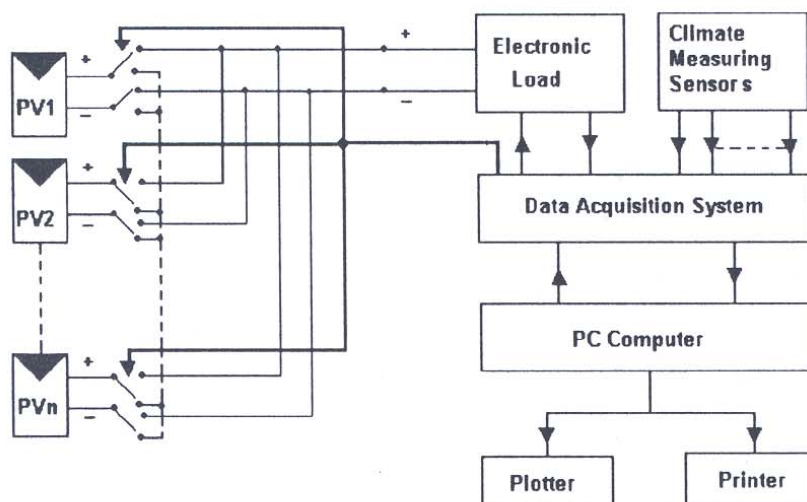

Fig. 3. Automatic system for measuring the $I-V$ characteristic of PV-modules.

It consists of a voltage controlled electronic load, climate parameters measuring sensors [solar radiation intensity on PV-module surface, PV module temperatures (on front and back sides), wind speed, relative humidity], a data acquisition system (DAS), a personal computer and plotter. The PV-modules installed outdoor are connected to the electronic load via relays. The $I-V$ curve of each module is measured by actuating the corresponding relay using a programmable variable voltage source in DAS which in its turn is controlled by the computer. Output signals of the electronic load (corresponding to voltage and current of the PV-module under test) and those of the climate measuring sensors are transferred to the analog input channels of the DAS. A computer program in Basic was developed for measuring the $I-V$ curves of the PV-modules and the associated climate parameters and to determine the different characteristic parameters of the module from its $I-V$ curve.

4. FIELD TESTING RESULTS

The amorphous silicon PV modules were mounted outside for long-term testing under natural weather conditions in Aqaba (located on the Red Sea coordinates: 29.33 N; 35.51 E). The weather conditions are considered as hard in summer where an absolute maximum temperature of 45°C is usually achieved.

Based from the measurements [8], the mean ambient temperature varies between 14.6°C in January and 31.95°C in July. The annual mean temperature is 24.14°C. The annual mean sunshine duration and wind speed are 9.49 hours / day and 3.2 m/s, respectively.

Aqaba enjoys a high solar energy potential from April to October and is absolutely cloudless. The annual mean of solar radiation amounts to 5.67 kWh/m² per day. The measured monthly mean solar radiation is illustrated in Fig. 4.

4.1. $I-V$ Characteristic

The $I-V$ characteristics of the amorphous modules were measured monthly along a test period of three years. During the test period, both modules were permanently installed outdoors under natural weather conditions. Figure 5 and Fig. 6 illustrate two selected $I-V$ curves for each module of the two types 1 and 2 (Type 1 SOVONICS / USA; Type 2 ARCOG 4000 / USA). In both sets of graphs the first curve was measured for each new module at the beginning of the operation (May 97) while the second curve was measured after three years of operation (May 99). All curves were measured at the same solar radiation intensity (980 W/m²) and the same module (cell) temperature (44°C), in order to secure correct evaluation and comparison.

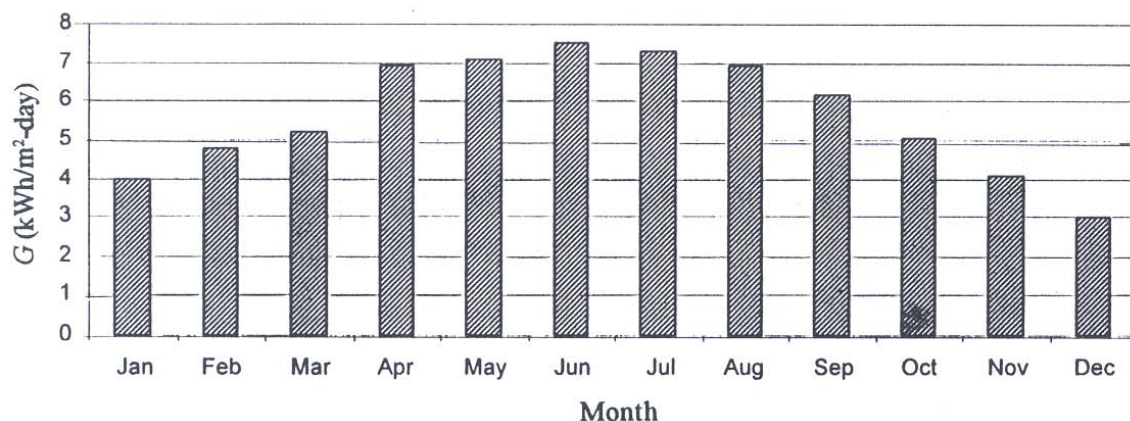

Fig. 4. Monthly mean solar radiation in Aqaba (Red Sea).

The shrinkage of the initial I - V curves of each module are shown in Fig. 5 and Fig. 6. This shrinkage is a reliable indicator for degradation of the amorphous modules after three years of operation. Based on these I - V curves the related characteristic parameters of the modules were computed by using the equations in section 3. The obtained results are illustrated in Table 1.

Table 1 Alterations of the Performance Parameters of Two Amorphous PV-module Types During a Three-Year Test Period

$E_{st} = 980 \text{ W/m}^2$		$T_{pv} = 44 \text{ C}^\circ$						
Module No.	Test Month	I_{sc} A	V_{oc} V	P_{max} W	η_{pv} %	F_f %	R_{sc} Ω	R_{oc} Ω
1	5/97	2.37	22.39	33.52	4.93	63.7	192	2
1	5/99	2.12	21.49	24.74	3.46	53.5	167.7	2.94
2	5/97	2.19	23.5	34.30	6.57	65.8	256.48	1.63
2	5/99	1.91	20.3	22.34	4.4	54.0	14.9	2.23

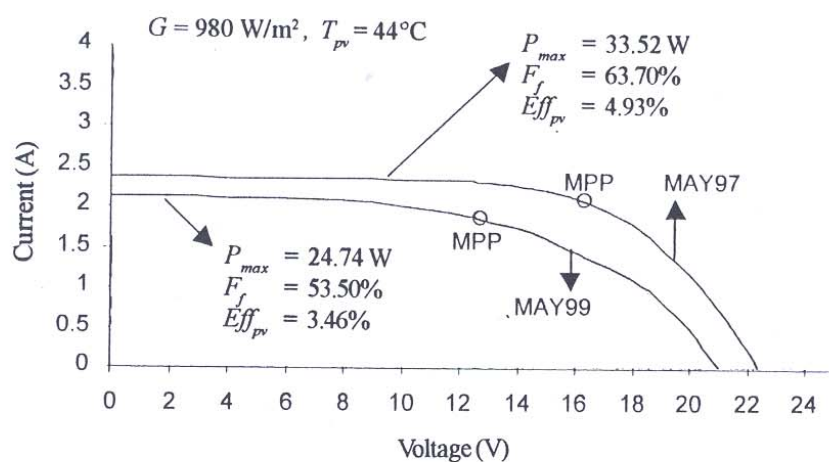

Fig. 5. I - V curves of the amorphous PV-module type 1 measured during the first three years of operation.

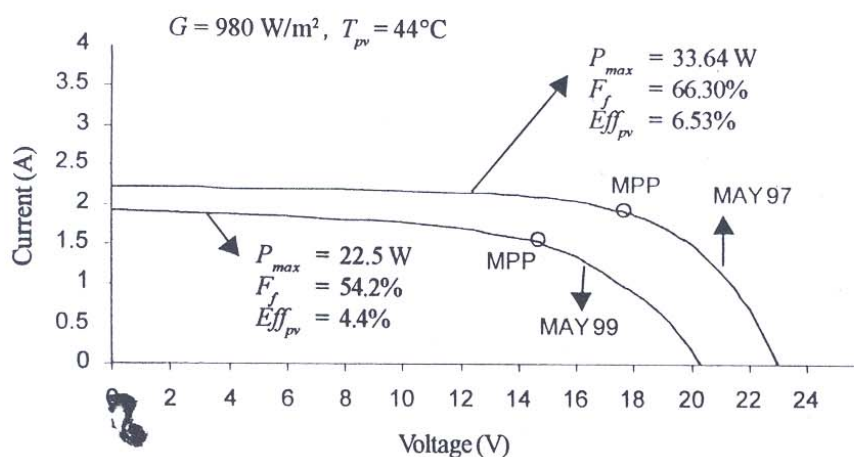

Fig. 6. I - V curves of the amorphous PV-module type 2 measured during the first three years of operation.

It is evident that the degradation of the peak power, the efficiency, the fill factor, the open circuit voltage and the short circuit current for both amorphous module types are remarkable. The performed measurements had shown that the highest degradation occurs during the first 1.5 years of operation. Calculating the degradation by percentage over the test period, the following results were obtained for both PV- modules:

<u>PV- Module No. 1</u>	<u>PV- Module No. 2</u>
$P_{max} = 20.5\%$	$P_{max} = 31.65\%$
$\eta_{pv} = 23.3\%$	$\eta_{pv} = 32.57\%$
$F_f = 12.4\%$	$F_f = 15.04\%$
$V_{oc} = 3.8\%$	$V_{oc} = 8.5\%$
$I_{sc} = 6.33\%$	$I_{sc} = 11.4\%$

The degradation of the characteristic parameters within the second 1.5 years of operation is relatively small.

As mentioned in section 3, measurement of R_{sc} and R_{oc} is a key parameter for quantifying the degradation of the amorphous module parameters. Considering Eq. (5), R_{sc} provides direct information about the effective $(\mu\tau)_{eff}$ - product, which represents a measure for the degradation of the i -layer of the cell or the module (Steabler-Wronski effect [9]).

Table 1 illustrates a degradation of R_{sc} (during the test period of 3 years) amounting to 24.3Ω for module 1 and 107.48Ω for module 2 which correspond to 12.66% and 41.9%, respectively, of their initial values. Since R_{sc} is directly proportional to $(\mu\tau)_{eff}$, these results apply for the degradation of the i -layer.

Furthermore, Table 1 illustrates an increase of R_{oc} amounting to 0.94Ω for module 1 and 0.6Ω for module 2. Since the I - V curves were measured at high illumination level (980W/m^2) the obtained values for R_{oc} represent also the increase of the series resistance R_s of module 1 and module 2, respectively, which also means an increase in the power loss for each module. Thereupon the relation between R_{sc} and R_{oc} , and the degradation of the output power, the fill factor and the efficiency of the modules are demonstrated.

4.2. Effect of Temperature

Increasing the cell temperature results in reduction of the open circuit voltage, the peak power and the efficiency of all crystalline and amorphous PV module types (shrinkage of the I - V curve).

Figure 7 and Fig. 8 show the peak power as a function of cell temperature at constant solar radiation intensity ($G = 980\text{W/m}^2$), obtained through continuous measurements of both amorphous PV types during the test period.

It is noticeable that the drop of the peak power with increasing cell temperature is higher during the first year of operation and amounts to $-120\text{mW}/^\circ\text{C}$ and $-98\text{mW}/^\circ\text{C}$ for the test modules 1 and 2, respectively. These values correspond to a drop in the open circuit voltage of $-58.82\text{mV}/^\circ\text{C}$ and $-51.5\text{mV}/^\circ\text{C}$, respectively. The maximum efficiency behaves as a function of cell temperature as the peak power. An efficiency drop of $-0.768\%/50^\circ\text{C}$ and $-0.847\%/50^\circ\text{C}$ were measured for modules 1 and 2, respectively, after 1.5 years of operation. Comparing these values to those obtained for crystalline modules [7], it is found that the amorphous module parameters are less temperature dependent.

5. CONCLUSIONS

Based on the experimental tests and study results, the following conclusions can be drawn:

- (a) Evaluation of I - V curves of amorphous PV-modules measured monthly, has shown that the short circuit resistance R_{sc} tends to stabilize after 1.5 years of outdoor exposure, whereas the open

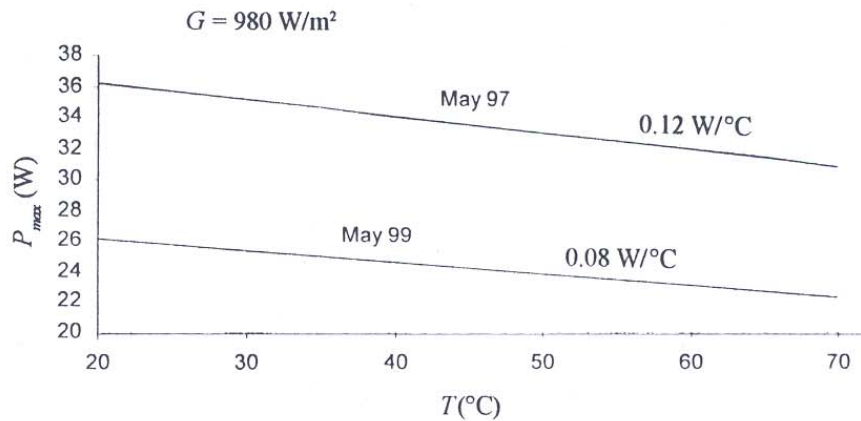

Fig. 7. The peak power as a function of cell temperature for the amorphous PV- module 1 at constant solar radiation.

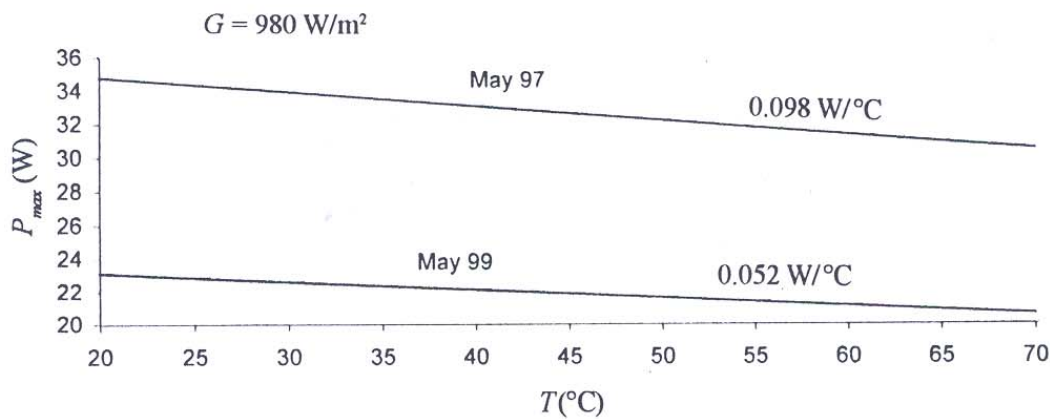

Fig. 8. The peak power as a function of cell temperature for the amorphous PV- module 2 at constant solar radiation.

circuit resistance R_{oc} continues increasing its value without any tendency to stabilize. The degradation in peak power of the module is mainly caused by the alteration of R_{sc} and R_{oc} which are related to R_{sh} and R_s , respectively.

- (b) In comparison with crystalline PV-modules the power degradation of amorphous PV-modules is extensively high especially during the first 1.5 years of operation, since it varies for most module types from 20% to 32% and thereafter tends to stabilize but on a low value. For crystalline types, the power degradation during the same period remains mostly under 7% [7].
- (c) The efficiency of amorphous modules degrades as the peak power while the fill factor degrades less yet its degradation is still considered high, since values from 12% to 15% of the initial value were registered during the first 1.5 years of operation.
- (d) Amorphous modules are less temperature dependent than the crystalline modules but this advantage loses its weight when considering conclusions (a) and (b).
- (e) The amorphous silicon solar technology still needs improvement not only with respect to raising the efficiency and reducing the peak watt price through new thin film materials, but more in stabilizing the peak power and fill factor. Hence, it is still early to utilize amorphous modules in building medium- and large-scale electric power plants.

6. REFERENCES

- [1] Hagedorn, G. 1992. Energieaufwand von Photovoltaik - und Windkraft -anlagen. IFE Schriftenreihe Heft 25 , TU Muenchen.
- [2] Srinivas, K.S. 1991. *Energy Investment and Production Costs of Amorphous Silicon PV Modules* Neuchaetel: Swiss Federal Dept. of Energy.
- [3] Merten, J., et al. 1998. Improved equivalent circuit and analytical model for amorphous silicon solar cells and modules. *IEEE Transactions on Electron Devices* 45 (2).
- [4] Hubin, J. and Shah, A.V. 1995. Effect of recombination function on the collection in a p-i-n solar cell. *Philos. Mag. B* 72 (6).
- [5] Hubin, J., et al. 1992. Effects of dangling bonds on the recombination function in amorphous semiconductors. *Philos. Mag. Lett.* Vol. 66.
- [6] Mahmoud, Marwan and Nabhan, Ismail. 1990. Analytical and graphical methods for determination of solar cell parameters and investigations of shadowing effect. *International Journal of Solar Energy* Vol. 9.
- [7] Mahmoud, Marwan and Nabhan, Ismail. 1986. Outdoor testing of photovoltaic modules and systems. *Royal Scientific Society* 14 (87/3).
- [8] Mahmoud, Marwan and Nabhan, Ismail. 1990. Determination of optimum tilt angle of single and multi rows of photovoltaic arrays for selected sites in Jordan. *Solar and Wind Technology* 7(6).
- [9] Staebler, D.L. and Wronski, C.R. 1977. Reversible conductivity changes in discharge - produced amorphous silicon. *Appl. Phys. Lett.* Vol. 31.